Telemecanique Sensors for Food & Beverage industry

The essential guide



Simply easy!™

Telemecanique Sensors

Simply easy!™

Telemecanique brand has a 9 decades history manufacturing factory automation and safety sensors. Telemecanique wide ranges are most reliable and robust hence second to none on the market.

Our aim is to **simplify the life of our customers**, allowing them to concentrate on their core added value and machine performance. This is why Telemecanique Sensors design and manufacture their products based on the following values:

- **Simplicity and modularity**
- **Easy to choose and select**
- **Easy to install and maintain**
- **Expert services to share our know-how**

Connect with the experts



- > A dedicated Sales team: trained and experienced sales professionals are available to help you with any sensing application.
- > Telemecanique Sensors team: are available for pre and post sales support. We become an extension of your team and we share our expertise with you.

www.tesensors.com

Contents



Inductive proximity sensors OsiSense XS	2 to 5
<i>Detection without contact of metal objects</i>	
Photo-electric sensors OsiSense XU	6 to 9
<i>Detection without contact of any object</i>	
Ultrasonic sensors OsiSense XX	10 to 12
<i>Detection without contact of any object</i>	
Rotary encoders OsiSense XCC	13
<i>Opto-electronic detection</i>	
Radio frequency identification OsiSense XG	14 to 15
<i>13.56 MHz RFID detection</i>	
Sensors for Safety Preventa XCS	16 to 17
<i>Detection without contact</i>	
Cabling system OsiSense XZC	18
<i>Pre-wired female connectors and jumper cables</i>	
Reflectors OsiSense XUZC	19
<i>Compatibility with photo-electric sensors</i>	
Technical informations	20 to 21
<i>Ecolab certification, degrees of protection provided by enclosure IP code</i>	

certified

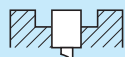

Non flush mountable



Flush mountable



Type		M12	M18	M30
Nominal sensing distance S_n	Flush mountable	6 mm	10 mm	20 mm
	Non flush mountable	10 mm	20 mm	40 mm
Operating zone (mm)	Flush mountable	0...4.8	0...8	0...16
	Non flush mountable	0...8	0...16	0...32
Suitability for flush mounting (metal environment)		Flush mountable or non flush mountable depending on model		
Case material		Full stainless steel 316L front face and housing in one piece		
Product certification		CE - cULus		
Temperature range (°C)		-25...+85		
Degree of protection (conforming to IEC 60529)		IP 68 (5 meters underwater for 1 month) and IP 69K (conforming to DIN 40050)		

Sensors for DC applications (solid-state output: transistor)

Connection						
3-wire	PNP	NO function	Flush mountable	XS912S1PAM12	XS918S1PAM12	XS930S1PAM12
			Non flush mountable	XS912S4PAM12	XS918S4PAM12	XS930S4PAM12
Supply voltage limits, min./max. (V) including ripple				10...30		
Switching capacity, max. (mA)				≤ 200 with overload and short-circuit protection		
Switching frequency (Hz)			Flush mountable	600	300	100
			Non flush mountable	400	200	90
Short-circuit protection (★) / LED output state indicator (⊗)				★ / ⊗		
Voltage drop, closed state (V) at I nominal				≤ 2		
Connection				M12 connector		

Accessories

Pre-wired M12 connectors

Female, 5-pin, 4 wires, IP 69K stainless steel clamping ring

Straight connector



2 m cable	XZCPA1141L2
5 m cable	XZCPA1141L5
10 m cable	XZCPA1141L10

Elbowed connector



2 m cable	XZCPA1241L2
5 m cable	XZCPA1241L5
10 m cable	XZCPA1241L10



Type	M12	M18	Ø 18 plain	M30
Nominal sensing distance Sn	7 mm	12 mm	12 mm	22 mm
Operating zone (mm)	0 ... 5.6	0 ... 9.6	0 ... 9.6	0 ... 17.6
Suitability for flush mounting (metal environment)	Non flush mountable			
Case material	Stainless steel 316 L			
Product certification	CE - UL - CSA - CCC - C-TICK			
Temperature range (°C)	- 25...+ 85			
Degree of protection (conforming to IEC 60529)	Pre-cabled: IP 68 (with connector: IP 67) and IP 69K conforming to DIN 40050			

Sensors for DC applications (solid-state output: transistor)

Connection			Pre-cabled, non poisonous PVC (2 m)			
Dimensions (mm)			M12 x 50	M18 x 60	Ø 18 x 60	M30 x 62
3-wire	PNP	NO function	XS212SAPAL2	XS218SAPAL2	XS2L2SAPAL2	XS230SAPAL2
	NPN	NO function	XS212SANAL2	XS218SANAL2	XS2L2SANAL2	XS230SANAL2
Connection			M12 connector			
Dimensions (mm)			M12 x 61	M18 x 70	Ø 18 x 70	M30 x 70
3-wire	PNP	NO function	XS212SAPAM12	XS218SAPAM12	XS2L2SAPAM12	XS230SAPAM12
	NPN	NO function	XS212SANAM12	XS218SANAM12	XS2L2SANAM12	XS230SANAM12
Supply voltage limits, min./max. (V) including ripple			10...58			
Switching capacity, max. (mA)			≤ 200			
Switching frequency (Hz)			2500	1000		500
Short-circuit protection (★) / LED output state indicator (⊗)			★ / ⊗			
Voltage drop, closed state (V) at I nominal			≤ 2			

Multi-current/multi-voltage sensors for AC/DC applications

Connection			Pre-cabled, non poisonous PVC (2 m)			
Dimensions (mm)			–	M18 x 60	–	M30 x 62
2-wire (1)	AC/DC	NO function	–	XS218SAMAL2	–	XS230SAMAL2
Connection			1/2" - 20 UNF connector			
Dimensions (mm)			–	M18 x 72	–	M30 x 74
2-wire (1)	AC/DC	NO function	–	XS218SAMAU20	–	XS230SAMAU20
Supply voltage limits, min./max. (V) 50-60 HZ			–	20 ... 264	–	20 ... 264
Switching capacity, max. (mA)			–	300 AC / 200 DC	–	300 AC / 200 DC
Switching frequency (Hz)			–	25 AC / 1000 DC	–	25 AC / 300 DC
LED output state indicator (⊗)			–	⊗	–	⊗
Voltage drop, closed state (V) at I nominal			–	≤ 5.5	–	≤ 5.5
Residual current, open state (mA)			–	≤ 0.8	–	≤ 0.8

(1) For these sensors without short-circuit protection, it is essential to connect a 0.4 quick-blow fuse in series with the load.

Accessories

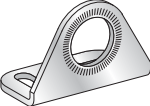
Fixing brackets		M12 pre-wired connectors		1/2" pre-wired connectors									
Plastic 	fixing centres 24.1 mm, with locking screw for sensor	Female, 5-pin, 4 wires, stainless steel clamping ring		Female, 3-pin, 3 wires, stainless steel clamping ring									
	<table border="1"> <tr> <td>Ø 18 plain</td> <td>XUZB2005</td> </tr> </table>	Ø 18 plain	XUZB2005	Straight connector	5 m cable	XZCPA1141L5	Straight connector	5 m cable	XZCPA1865L5				
Ø 18 plain	XUZB2005												
Stainless steel 	<table border="1"> <tr> <td>Ø 12</td> <td>XSZBS12</td> </tr> <tr> <td>Ø 18</td> <td>XUZA118</td> </tr> <tr> <td>Ø 30</td> <td>XSZBS30</td> </tr> </table>	Ø 12	XSZBS12	Ø 18	XUZA118	Ø 30	XSZBS30	Elbowed connector	5 m cable	XZCPA1241L5	Elbowed connector	5 m cable	XZCPA1965L5
	Ø 12	XSZBS12											
	Ø 18	XUZA118											
Ø 30	XSZBS30												



Type	M12	M18	M30
Nominal sensing distance Sn	7 mm	12 mm	22 mm
Operating zone (mm)	0 ... 5.6	0 ... 9.6	0 ... 17.6
Suitability for flush mounting (metal environment)	Non flush mountable		
Case material	Plastic		
Product certification	CE - UL - CSA - CCC - C-TICK		
Temperature range (°C)	- 25...+ 85		
Degree of protection (conforming to IEC 60529)	Pre-cabled: IP 68 (with connector: IP 67) and IP 69K conforming to DIN 40050		

Sensors for DC applications (solid-state output: transistor)

Connection			Pre-cabled PvR (2 m)		
Dimensions (mm)			M12 x 50	M18 x 60	M30 x 62
3-wire	PNP	NO function	XS212AAPAL2	XS218AAPAL2	XS230AAPAL2
	NPN	NO function	XS212AANAL2	XS218AANAL2	XS230AANAL2
Connection			M12 connector		
Dimensions (mm)			M12 x 61	M18 x 70	M30 x 70
3-wire	PNP	NO function	XS212AAPAM12	XS218AAPAM12	XS230AAPAM12
	NPN	NO function	XS212AANAM12	XS218AANAM12	XS230AANAM12
Supply voltage limits, min./max. (V) including ripple			10...58		
Switching capacity, max. (mA)			≤ 200		
Switching frequency (Hz)			2500	1000	500
Short-circuit protection (★) / LED output state indicator (⊗)			★ / ⊗		
Voltage drop, closed state (V) at I nominal			≤ 2		

Multi-current/multi-voltage sensors for AC/DC applications

Connection			Pre-cabled PvR (2 m)		
Dimensions (mm)			–	M18 x 60	M30 x 60
2-wire (1)	AC/DC	NO function	–	XS218AAMAL2	XS230AAMAL2
Connection			1/2"-20 UNF connector		
Dimensions (mm)			–	M18 x 70	M30 x 74
2-wire (1)	AC/DC	NO function	–	XS218AAMAU20	XS230AAMAU20
Supply voltage limits, min./max. (V) 50-60 HZ			–	20 ... 264	20 ... 264
Switching capacity, max. (mA)			–	300 AC / 200 DC	300 AC / 200 DC
Switching frequency (Hz)			–	25 AC / 1000 DC	25 AC / 300 DC
LED output state indicator (⊗)			–	⊗	⊗
Voltage drop, closed state (V) at I nominal			–	≤ 5.5	≤ 5.5
Residual current, open state (mA)			–	≤ 0.8	≤ 0.8

(1) For these sensors without short-circuit protection, it is essential to connect a 0.4 quick-blow fuse in series with the load.

Accessories

Fixing brackets

Stainless steel

for sensor

Ø 12	XSZBS12
Ø 18	XUZA118
Ø 30	XSZBS30

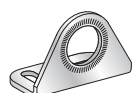

M12 pre-wired connector

Female, 5-pin, 4 wires, stainless steel clamping ring

Straight connector 5 m **XZCPA1141L5**

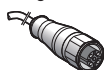

Elbowed connector 5 m **XZCPA1241L5**



1/2" pre-wired connector

Female, 3-pin, 3 wires, stainless steel clamping ring

Straight connector 5 m **XZCPA1865L5**



Elbowed connector 5 m **XZCPA1965L5**



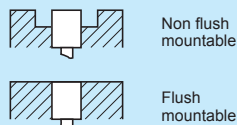

	M8	M12	M18	M30
Nominal sensing distance S_n	2.5 mm	4 mm	8 mm	15 mm
Operating zone (mm)	0...2	0...3.2	0...6.4	0...12
Suitability for flush mounting (metal environment)	Non flush mountable			
Case material	Plastic			
Temperature range (°C)	- 25...+ 70			
Product certification	CE - UL - CSA - CCC - C-TICK			
Degree of protection (conforming to IEC 60529)	IP 67	pre-cabled: IP 68 (with connector: IP 67)		

Sensors for DC applications

Connection			Pre-cabled, PvR (2 m)			
Dimensions (mm) Ø x L or W x H x D			M8 x 33	M12 x 33	M18 x 33.5	M30 x 40.5
3-wire	PNP	NO function	XS4P08PA340	XS4P12PA340	XS4P18PA340	XS4P30PA340
		NC function	XS4P08PB340	XS4P12PB340	XS4P18PB340	XS4P30PB340
	NPN	NO function	XS4P08NA340	XS4P12NA340	XS4P18NA340	XS4P30NA340
		NC function	XS4P08NB340	XS4P12NB340	XS4P18NB340	XS4P30NB340
Connection			M8 connector			
Dimensions (mm) Ø x L or W x H x D			M8 x 42	M12 x 48	M18 x 48	M30 x 50
3-wire	PNP	NO function	XS4P08PA340S	XS4P12PA340D	XS4P18PA340D	XS4P30PA340D
		NC function	XS4P08PB340S	XS4P12PB340D	XS4P18PB340D	XS4P30PB340D
	NPN	NO function	XS4P08NA340S	XS4P12NA340D	XS4P18NA340D	XS4P30NA340D
		NC function	XS4P08NB340S	XS4P12NB340D	XS4P18NB340D	-
Supply voltage limits, min./max. (V) including ripple			10...38			
Switching capacity, max. (mA)			200			
Short-circuit protect. (★) / LED output state indicator (⊗)			★ / ⊗			
Voltage drop, closed state (V) at I nominal			≤ 2			
Switching frequency (Hz)			5000		2000	1000

Multi-current/multi-voltage sensors for AC/DC applications

Connection			Pre-cabled, PvR (2 m)			
Dimensions (mm) Ø x L or W x D x H			M8 x 50	M12 x 50	M18 x 60	M30 x 60
2-wire	AC/DC	NO function	XS4P08MA230	XS4P12MA230	XS4P18MA230	XS4P30MA230
		not short-circuit protected (1) NC function	XS4P08MB230	XS4P12MB230	XS4P18MB230	XS4P30MB230
Connection			1/2" connector			
Dimensions (mm) Ø x L or W x H x D			M8 x 61	M12 x 61	M18 x 70	M30 x 70
2-wire	AC/DC	NO function	XS4P08MA230K	XS4P12MA230K	XS4P18MA230K	XS4P30MA230K
		not short-circuit protected (1) NC function	XS4P08MB230K	XS4P12MB230K	XS4P18MB230K	XS4P30MB230K
Supply voltage limits, min./max. (V) including ripple			20...264			
Switching capacity, max. (mA)			100	200	300 AC / 200 DC	300 AC / 200 DC
LED output state indicator (⊗)			⊗			
Residual current, open state (mA)			≤ 0.6			
Voltage drop, closed state (V) at I nominal			≤ 5.5			
Switching frequency (Hz)			25 AC / 3000 DC		25 AC / 2000 DC	25 AC / 1000 DC

(1) For these sensors without short-circuit protection, it is essential to connect a 0.4 A quick-blow fuse in series with the load.

Fixing for cylindrical sensors

Fixing clamp with indexing pin for cylindrical sensors

M8	XSZB108
M12	XSZB112
M18	XSZB118

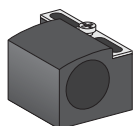

M8 and M12 pre-wired connectors

M8 female, 3-pin, 3 wires, stainless steel clamping ring	
Straight connector	M8 XZCPA0566L5
M12 female, 5-pin, 4 wires, stainless steel clamping ring	
Elbowed connector	M12 XZCPA1141L5 M12 XZCPA1241L5

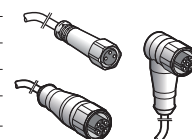

1/2" pre-wired connectors

Female, 3-pin, 3 wires, stainless steel clamping ring	
Straight connector	5 m XZCPA1865L5
Elbowed connector	5 m XZCPA1965L5

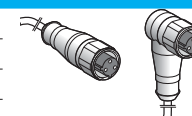

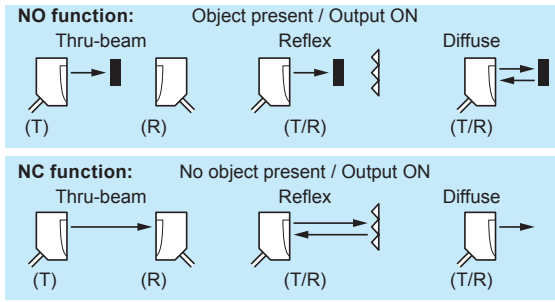

System			Plastic Cable	M12 connector
Diffuse	Sensing distance		0.15 m	
		DC 3 wire NO	PNP	XUB4APANL2
		NPN	XUB4ANANL2	XUB4ANANM12
Diffuse adjustable	Sensing distance		0.6 m	
		DC 3 wire NO	PNP	XUB5APANL2
		NPN	XUB5ANANL2	XUB5ANANM12
Reflex polarised	Sensing distance		2 m (1)	
		DC 3 wire NO	PNP	XUB9APANL2
		NPN	XUB9ANANL2	XUB9ANANM12
Reflex	Sensing distance		4 m (1)	
		DC 3 wire NO	PNP	XUB1APANL2
		NPN	XUB1ANANL2	XUB1ANANM12
Thru-beam	Sensing distance		15 m	
		DC 3 wire NO	PNP	XUB2APANL2R
		NPN	XUB2ANANL2R	XUB2ANANM12R
Output function	NO		A	A
	NC		B	B
Thru-beam transmitter		DC	XUB2AKSNL2T	XUB2AKSNM12T
Case material			Plastic	
Degree of protection (conforming to IEC 60529)			IP 65 / IP 67	IP 65 / IP 67 / IP 69K
Temperature range (°C)			- 25...+ 55 °C	
Product certification			CE, UL, CSA	
Supply voltage limits, min./max. (V) including ripple			10...36	
Switching capacity, max. (mA) / Switching frequency (Hz)			100/500	

(1) With reflector XUZY50 to be ordered separately.

System			Plastic Cable	M12 connector
Multimode	Sensing distance	Background suppression	0.12 m	
		Diffuse	0.3 m	
		Reflex polarised	3 m	
		Thru-beam	20 m	
Output type	DC 3 wire NO/NC programmable	PNP	XUB0APSNL2	XUB0APSNM12
		NPN	XUB0ANSNL2	XUB0ANSNM12
Thru-beam transmitter			XUB0AKSNL2T	XUB0AKSNM12T
Case material			Plastic	
Degree of protection (conforming to IEC 60529)			IP 65 / IP 67	IP 65 / IP 67 / IP 69K
Temperature range (°C)			- 25...+ 55 °C	
Product certification			CE, UL, CSA	
Supply voltage limits, min./max. (V) including ripple			10...36	
Switching capacity, max. (mA) / Switching frequency (Hz)			100/250	

Accessories

Fixing bracket

Stainless steel

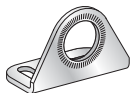

For sensor
Ø 18 **XUZA118**

M12 pre-wired connectors

Female, 5-pin, 4 wires, stainless steel clamping ring

Straight connector

2 m **XZCPA1141L2**



Elbowed connector

5 m **XZCPA1241L5**





System			M18 Metal Cable	M12 connector	M18 Metal with 90° head Cable	M12 connector
Diffuse	Sensing distance		0.1 m			
Output type	DC 3 wire NO/NC programmable	PNP	XU5N18PP341	XU5N18PP341D	XU5N18PP341W	XU5N18PP341WD
		NPN	XU5N18NP341	XU5N18NP341D	XU5N18NP341W	XU5N18NP341WD
Reflex polarised	Sensing distance		2 m (1)			
Output type	DC 3 wire NO/NC programmable	PNP	XU9N18PP341	XU9N18PP341D	XU9N18PP341W	XU9N18PP341WD
		NPN	XU9N18NP341	XU9N18NP341D	XU9N18NP341W	XU9N18NP341WD
Reflex	Sensing distance		4 m (1)			
Output type	DC 3 wire NO/NC programmable	PNP	XU1N18PP341	XU1N18PP341D	XU1N18PP341W	XU1N18PP341WD
		NPN	XU1N18NP341	XU1N18NP341D	XU1N18NP341W	XU1N18NP341WD
Thru-beam	Sensing distance		15 m (2)			
Output type	DC 3 wire NO/NC programmable	PNP	XU2N18PP341	XU2N18PP341D	XU2N18PP341W	XU2N18PP341WD
		NPN	XU2N18NP341	XU2N18NP341D	XU2N18NP341W	XU2N18NP341WD
Case material			Stainless steel 304			
Degree of protection (conforming to IEC 60529)			IP 67		IP 67	
Temperature range (°C)			- 25...+ 55 °C			
Product certification			CE, UL, CSA			
Supply voltage limits, min./max. (V) including ripple			10...30			
Switching capacity, max. (mA) / Switching frequency (Hz)			100/500			

(1) With reflector XUZC50 included. (2) Transmitter and receiver included.

System			M18 Metal Cable	M12 connector	M18 Metal with 90° head Cable	M12 connector
Multimode	Sensing distance	Diffuse	0.12 m		0.11 m	
		Diffuse adjustable	0.3 m		0.3 m	
		Reflex polarised	3 m		2 m	
		Thru-beam	20 m		10 m	
Output type	DC 3 wire NO/NC programmable	PNP	XUB0SPSNL2	XUB0SPSNM12	XUB0SPSNWL2	XUB0SPSNWM12
		NPN	XUB0SNSNL2	XUB0SNSNM12	XUB0SNSNWL2	XUB0SNSNWM12
Thru-beam transmitter			XUB0SKSNL2T	XUB0SKSNL12T	XUB0SKSNWL2T	XUB0SKSNWL12T
Case material			Stainless steel 304			
Degree of protection (conforming to IEC 60529)			IP 65 / IP 67	IP 65 / IP 67 / IP 69K	IP 65 / IP 67	IP 65 / IP 67 / IP 69K
Temperature range (°C)			- 25...+ 55 °C			
Product certification			CE, UL, CSA			
Supply voltage limits, min./max. (V) including ripple			10...36			
Switching capacity, max. (mA) / Switching frequency (Hz)			100/250			

Reflectors

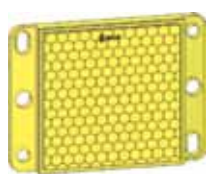

ECOLAB® certified reflector, IP69K, resistant to detergents up to 140 °C

50 x 50 mm **XUZC50CR**
40 x 18 mm **XUZCR0402CR**

Ø 80 **XUZC80**

For compatibility and effect on sensing range, see page 19

50 X 50 mm **XUZC50**
40 X 60 mm **XUZC60S11**

Photo-electric sensors For detection of transparency materials Cylindrical, stainless steel and plastic



Sensor type	M18 Metal		M18 Metal with 90° head	
	Cable	M12 connector	Cable	M12 connector
Sensing distance with XUZC50HP reflector 50x50 mm (1)	1,40 m		0,80 m	
Case material	Stainless steel 304			
Temperature range (°C)	0...+ 55			
Degree of protection (conforming to IEC 60529)	IP 65 / IP 67	IP 65 / IP 67 / IP 69K (IP 69K conforming to DIN 40050)	IP 65 / IP 67	IP 65 / IP 67 / IP 69K (IP 69K conforming to DIN 40050)
Product certification	CE, UL, CSA			
References	PNP (NO or NC function - programmable)	XUBTSPSNL2	XUBTSPSNM12	XUBTSPSWL2
	NPN (NO or NC function - programmable)	XUBTSNSNL2	XUBTSNSNM12	XUBTSNSWL2
Supply voltage limits, min./max. (V) including ripple	10...32			
Maximum switching frequency (Hz) / Switching capacity, max. (mA)	1000 / 100 with overload and short-circuit protection			

(1) reflector XUZC50HP supplied

Sensor type	M18 Plastic	
	Cable	M12 connector
Sensing distance with XUZC50HP reflector 50x50 mm (1)	1,40 m	
Fixing	M18 x 1	
Material	Case	Plastic PBT
	Lens	PMMA
Temperature range (°C)	0...+ 55	
Degree of protection (conforming to IEC 60529)	IP 65 / IP 67	IP 65 / IP 67 / IP 69K (IP 69K conforming to DIN 40050)
Product certification	CE, UL, CSA, C-Tick	
References	PNP (NO function)	XUBTAPSNL2
	NPN (NO function)	XUBTANSNL2
Supply voltage limits, min./max. (V) including ripple	10...32	
Maximum switching frequency (Hz) / Switching capacity, max. (mA)	500 / 100 with overload and short-circuit protection / LED output state	

(1) reflector XUZC50HP supplied

Accessories

M12 pre-wired connectors

IP69K, female, 5-pin, 4 wires, stainless steel clamping ring

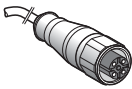

Straight	
2 m	XZCPA1141L2
5 m	XZCPA1141L5
10 m	XZCPA1141L10

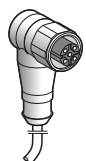

Elbowed	
2 m	XZCPA1241L2
5 m	XZCPA1241L5
10 m	XZCPA1241L10

Fixing bracket

Stainless steel



For sensor	
Ø 18	XUZA118

Reflectors

High precision reflector
For compatibility and effect
on sensing range, see page 19



Dimensions	
50 x 50 mm	XUZC50HP
20 x 32 mm	XUZCR0201CRHP
40 x 19 mm	XUZCR0401CRHP



Application	Stainless steel version for resistance to harsh agents		
System	Background suppression	Polarised reflex	Thru-beam
Sensing distance	0.03...0.55 m	0.4...6 m (1)	0...15 m
Fixing (mm)	2 x Ø 4.3 holes ...		
Case material	Stainless steel 316L		
Temperature range (°C)	-20 ... +60 °C (100 °C for cleaning and sterilization phase whilst not in service)		
Degree of protection (conforming to IEC 60529)	IP 67 (IP69K conforming to DIN 40050)		
Product certification	CE, Ecolab		
Dimensions (mm) H x W x D	50 x 50 X 23		
Type of transmission	Read beam		
Sensitivity adjustment	Teach mode		

Sensors for DC applications (solid-state output: transistor)

Connection	M12 connector - 4 pin			
Output type	DC 4 wire NO/NC PNP programmable	XUK8SPSMM12	XUK9SPSMM12	XUK2SKSMM12T (transmitter) XUK2SPSMM12R (receiver)
Supply voltage limits, min./max. (V) including ripple	10...30			
Switching capacity, max. (mA) / Switching frequency (Hz)	100 / 400		100 / 600	100 / 500

(1) With reflector XUZC50 to be ordered separately.



Compact 50x50mm

Application				
System	Back ground suppression	Diffuse	Polarised reflex	Thru-beam
Sensing distance	0.8 m	1.2 m	12 m (2)	25 m
Fixing (mm)	2 x Ø 4.3 holes / fixing centres 30			
Case material	Plastic			
Setting-up assistance LEDs ☉	☉			
Temperature range (°C) /	-20...+60 °C			
Degree of protection (conforming to IEC 60529)	IP67 (IP69K conforming to DIN 40050)			
Product certification	CE, Ecolab			
Dimensions (mm) H x W x D	50 x 50 X 23			
Sensitivity adjustment	Potentiometer	Teach mode		

Sensors for DC applications (solid-state output: transistor)

Connection	M12 connector - 4 pin				
Output type	DC 4 wire NO/NC PNP programmable	XUK8LAPPNM12 (3)	XUK5LAPSMM12 (3)	XUK9LAPSMM12 (3)	XUK2LAKSMM12T (3) (4) XUK2LAPSMM12R (3) (5)
Supply voltage limits, min./max. (V) including ripple	12...30				
Switching capacity, max. (mA) / Switching frequency (Hz)	100 / ≤ 1000		100 / ≤ 600	100 / ≤ 2000	100 / ≤ 3500
Overload and short-circuit protection (★) / LED output state indicator (☉)	★ / ☉				

(2) With reflector XUZC50HP to be ordered separately.

(3) Fixing bracket: XUZA51S to be ordered separately.

(4) Transmitter

(5) Receiver



	M12	M18	Mini-flat	Flat
Nominal sensing distance Sn	5 or 10 cm (1)	15 or 50 cm (1)	10 cm	25 cm
Mode proximity or reflex				
Mode thru-beam	20 cm	61 or 100 cm (1)	20 cm	61 or 100 cm (1)
Operating zone for proximity mode	0.64...5.1 cm (XX512A1...) 0.64...10.2 cm (XX512A2...)	1.9...15.2 cm (XX518A1...) 5.1...50.8 cm (XX518A3...)	0.62...10.2 cm	5.1...25.4 cm
Sensitivity adjustment	Fixed	Adjustable using remote control (2) or fixed (3)	Fixed	
Product certification	CE			
Temperature range (°C)	-20...+65	0...+50 (XX518A1.....) / -20...+65 (XX●18A3.....)	-20...+65	0...+50
Degree of protection (conforming to IEC 60529)	IP 67			
Dimensions (mm) Ø x L	M12 x 50	M18 x 65	33 x 19 x 7.6	74 x 30 x 16
Supply voltage limits, min./max. (V) including ripple	10...28			
Short-circuit protection (★)	★			

Proximity or Reflex mode with “Discrete” output for DC applications (24 V)

Connection			M8 connector	M12 connector	M12 on 0.15 m flying lead	M12 connector
Proximity mode 3-wire	PNP	NO function	XX512A2PAM8 (10 cm)	XX518A3PAM12 (50 cm)	XX7F1A2PAL01M12	XX7K1A2PAM12
		NO function	XX512A2NAM8 (10 cm)	XX518A3NAM12 (50 cm)	XX7F1A2NAL01M12	XX7K1A2NAM12
Proximity mode 4-wire	PNP/NPN	NO + NC function	XX512A1KAM8 (5 cm)	XX518A1KAM12 (15 cm)	–	–
		NO + NC function	–	–	–	–
Reflex mode 3-wire	PNP/NPN	NO function	–	XXB18A3PAM12 (50 cm)	–	–
		NO function	–	–	–	–

Proximity - Application - monitoring levels

2 emptying levels	PNP NO function	–	XX218A3PHM12 (50 cm) (4)		
2 filling levels	PNP NO function	–	XX218A3PFM12 (50 cm) (4)		
Switching capacity, max. (mA)		<100			
LED output state indicator (⊗) / Power on LED (⊗)		⊗ / ⊗	⊗ / ⊗ (5)	⊗ / ⊗	
Voltage drop, closed state (V) at I nominal		<1			
Switching frequency (Hz)		125	40 / 80 (6)	100	80

(1) Depending on model. (2) For XX518A3. (3) For XX518A1, XXT18, XXR18. (4) 1 NO. (5) Except XX518A1 (6) For XX518A1.

Proximity mode with “Analogue” output for DC applications (24 V)

Connection			M8 connector	M12
4-wire	Analogue	0...10 mA output	–	XX918A3F1M12 (50 cm)
		4...20 mA output	–	XX918A3C2M12 (50 cm)
LED output state indicator (⊗) / Power on LED (⊗)			–	⊗ / ⊗

Thru-beam mode with “Discrete” output for DC applications (24 V)

Connection		M8 connector	M12 connector
4-wire	Receiver (NO/PNP + NO/NPN)	XXR12A8KAM8	XXR18A3KAM12 (0.61 m) XXR18A4KAM12 (1 m)
	Receiver (NC/PNP + NC/NPN)	XXR12A8KBM8	XXR18A3KBM12 (0.61 m) XXR18A4KBM12 (1 m)
	Transmitter	XXT12A8M8	XXT18A3M12 (0.61 m) XXT18A4M12 (1 m)
Temperature range (°C)		0...+60	-20...+65
Switching capacity, max. (mA)		<100	
LED output state indicator (⊗) / Power on LED (⊗)		⊗ / ⊗	– / –
Switching frequency (Hz)		125	40



Combined multi-fixing	Flat 80 x 80	M30			M30 Long range
50 cm	1 m	1 m		2 m	8 m
5.1...50.8 cm	0.1...1 m		0.05...0.99 m	0.12...2 m	0.3...8 m
Adjustable using remote control		Adjustable using teach mode			
-20...+65	0...+70				-20...+60
M 18 / 18 x 33 x 60	80 x 80 x 34	M30 x 78	IP 65	M30 x 85	M30 x 106

XX7V1A1PAM12	XX8D1A1PAM12	XX6V3A1PAM12	-	-	-
XX7V1A1NAM12	XX8D1A1NAM12	XX6V3A1NAM12	-	-	-
-	-	-	XX630A1KAM12	-	-
-	-	-	XX630A1PCM12	XX630A2PCM12	XX630A3PCM12
-	-	-	XX630A1NCM12	XX630A2NCM12	XX630A3NCM12
XXV1A1PAM12	XXBD1A1PAM12	XXBV3A1PAM12	-	-	-

			XX230A10PA00M12 (7)	XX230A20PA00M12 (7)	-
			XX230A11PA00M12 (7)	XX230A21PA00M12 (7)	-

40	70		10		2
			(7) 2 NO		

XX9V1A1F1M12	XX9D1A1F1M12	XX9V3A1F1M12	XX930A1A1M12	XX930A2A1M12	XX930A3A1M12
XX9V1A1C2M12	XX9D1A1C2M12	XX9V3A1C2M12	XX930A1A2M12	XX930A2A2M12	XX930A3A2M12

Accessories

Remote control

teach button for use with sensors XX●18A3●●●, XX●V1●●●, XX●V3●●● and XX●D1

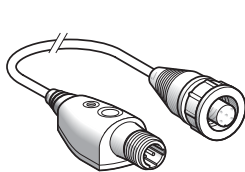

XXZPB100

M8 and M12 pre-wired female connectors

M8 female 3-pin 3 wires, stainless steel clamping ring for XX512A2

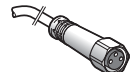

Straight connector
5 m cable **XZCPA0566L5**

M8 female 4-pin 4 wires, stainless steel clamping ring for XX512A1

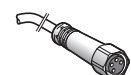

Straight connector
5 m cable **XZCPA0941L5**

M12 female 5-pin 4 wires, stainless steel clamping ring

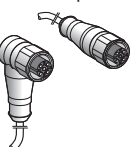

Straight connector
5 m cable **XZCPA1141L5**

Elbowed connector
5 m cable **XZCPA1241L5**

Fixing brackets



for sensor

Ø12	XSZBS12
Ø18	XUZA118
Ø30	XSZBS30



Sensor type	M30 silicone front face	M30 stainless steel front face
Nominal sensing distance Sn	1 m	
Operating zone	120..1000 mm adjustable using teach button	
Product certification with CE		
Supply voltage limits, min./max. (V) including ripple	10..28 V DC	
Degree of protection	IP 67	
Temperature range (°C)	0...+60	-20...+60
Connection type	M12 4-pin	
Dimensions (mm) Ø x L	M30 x 85	M30 x 96
Materials : Barrel / Coupler housing / Front face	303 / 303 / Silicone	303 / 304 / 304
Switching capacity, max. (mA)	100	
LED output state indicator (⊗)	⊗	
Short-circuit protection (★)	★	
Switching frequency (Hz)	10	

Proximity mode with “Discrete” output for DC applications (24 V)

4-wire	PNP/NPN	NO	–	XX630T1KA000M12
	PNP	NO/NC	XX630S1PCM12	–
	NPN	NO/NC	XX630S1NCM12	–

Proximity mode with “Analogue” output for DC applications (24 V)

4-wire	Analogue	0..10 V output	XX930S1A1M12	–
		4..20 mA output	XX930S1A2M12	XX930T1A4303M12

Accessories

M12 pre-wired connectors

IP69K, female, 5-pin, 4 wires, stainless steel clamping ring

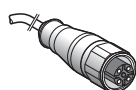

Straight	
2 m	XXCPA1141L2
5 m	XXCPA1141L5
10 m	XXCPA1141L10

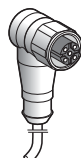

Elbowed	
2 m	XXCPA1241L2
5 m	XXCPA1241L5
10 m	XXCPA1241L10



Type		Incremental Ø 58	Absolute single turn	Absolute multiturn
Shaft Ø (mm)		Ø 10		
Type of shaft		Solid shaft		
Maximum rotational speed (rpm)		3000		3000
Maximum frequency (kHz)		300	100 (100 to 1000 SSI)	100 (100 to 500 SSI)
Maximum load radial/axial (daN)		25 / 50		25 / 25
Torque (N.cm)		0.4		
Product certification		CE		
Temperature range (°C)		- 30...+ 100	- 20...+ 90	- 20...+ 85
Degree of protection (conforming to IEC 60529)		IP 69K		
Supply voltage	Push-pull	5...30 V		11...30 V
Connection		Pre-cabled (2 m), axial		
Resolution (Points)	Output stage			
360	Push-pull	XCC1510SPA03Y	–	–
1024	Push-pull	XCC1501SPA11Y	–	–
5 000	Push-pull	XCC1510SPA50Y	–	–
8192	Push-pull	Gray	–	XCC2510SPA81KG
	SSI, 13 bits	Gray	–	XCC2510SPA81SGN
4096 points / 8192 turns	SSI, 25 bits	Gray	–	XCC3510SPA48SGN

Accessories

Shaft coupling

With spring

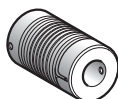

Bore diameter (encoder side)	Bore diameter (machine side)	Reference
10 mm	10 mm	XCCRAR1010S
10 mm	12 mm	XCCRAR1012S
10 mm	0.375"	XCCRAR10037S

Presentation



OsiSense XG is open to the majority of ISO 18000-3, ISO 15693 and ISO 14443 electronic tags. OsiSense XG integrates Modbus RTU, Uni-Telway, Modbus TCP/IP (using Ethernet box XGCSZ33ETH) and Profibus DP (with box XGSZ33PDP) protocols.

The OsiSense XG RFID offer comprises:

- 2 models of 13.56 MHz smart antenna (read/write)
- 11 models of 13.56 MHz electronic tags
- 1 portable RFID diagnostics terminal
- 3 models of network connection boxes plus connection and mounting accessories.

Setting-up

OsiSense XG smart antenna are simple to set-up:

- Integrated RFID and network functions
- No programming
- Automatic detection of the RFID electronic tags (read or write)
- Automatic setting of the communication parameters (speed, format, parity, protocol, etc.)
- Configuration of the network address (1 to 15) using badge included with the smart antenna
- Low sensitivity to metal environments.

Installation

OsiSense XG smart antenna easily integrate in flexible manufacturing production lines:

- quick connection using M12 connector
- screw fixing or clip-on mounting.



Smart antenna, 13.56 MHz	Flat form 40	Flat form 80
Dimensions (mm), W x H x D	40 x 40 x 15	80 x 80 x 26
Nominal sensing distance depending on tag (mm)	18 to 70	20 to 100
Type of associated tag	ISO 15693 and ISO 14443 standard tags. Automatic detection of the type of tag.	
Display	1 dual colour LED for the communication network, 1 dual colour LED for the RFID communication	
Conformity to standards	CE, EN 301489-1, EN 301489-3, ETS 300330-1 and ETS 300330-2, FCC part 15 - UL	
Degree of protection conforming to IEC 60529	IP 67	
Serial link	Type	RS 485
	Protocol	Modbus and Uni-Telway
	Speed (Bauds)	9600...115 200 (automatic detection)
Ambient air temperature (°C)	For operation: - 25...+ 70 °C, for storage: - 40...+ 85 °C	
Nominal supply voltage	24 VDC PELV (Protective Extra Low Voltage)	
Connection	M12, 5-pin male, shielded connector on flying lead. Only for connection to the communication network and the supply	
References	XGCS4901201	XGCS8901201



Electronic tags	Flat form 40	High temperature Disc (3)	ISO badge (1)	Disc	Flat form 26	Cylindrical	
Dimensions (mm), W x H x D	40 x 40 x 15	40 x 11	54 x 85.5 x 0.8	Ø 30 x 3	26 x 26 x 13	M18 x 1 x 12	
Type of memory	EEPROM						
Memory capacity (bytes)	3 408	256	256	112	256	256	
Nominal sensing distance (mm) (Read/Write)	With station XGCS49●	33	40	70	48	40	18
	With station XGCS89●	48	63	100	65	55	20
Time (ms)	Read	9.25 + 0.375 x n (2)	12 + 0.825 x n (2)	12 + 0.825 x n (2)	—		
	Write	13 + 0.8 x n (2)	20 + 11.8 x n (2)	20 + 11.8 x n (2)	12 + 5.6 x n (2)	20 + 11.8 x n (2)	19 + 4.1 x n (2)
Degree of protection conforming to IEC 60529	IP 68		IP 65		IP 68		
Standard supported	ISO 14443	ISO 15693	ISO 15693				
Mounting on metal support	Yes		No		Yes	No	
References	XGHB444345	XGHB411346	XGHB90E340	XGHB320345	XGHB221346	XGHB211345	

(1) Customised versions on request. (2) n = number of 16-bit words. (3) For operation - 25...+ 90 °C, for storage - 25...+ 120 °C (+ 160 °C for 50 hours, + 220 °C max. peak).



Connection boxes	Ethernet Modbus TCP/IP box	Profibus box	EtherNet/IP box
Dimensions (mm), W x H x D	130 x 80 x 51		130 x 80 x 51
Protocols	Modbus TCP/IP	Profibus DP	EtherNet/IP
Supply voltage	24 VDC PELV. M12, 4-pin male, A coding, connector		
Conformity to standards	CE - UL	CE	CE
Station connection	M12, 5-pin female, A coding, connector		
Degree of protection conforming to IEC 60529	IP 65		
References	XGSZ33ETH	XGSZ33PDP	XGSZ33EIP



Terminal	Portable 13.56 MHz RFID diagnostics terminal
Dimensions (mm), W x H x P	78 x 153 x 27
Function	Read/Write operations on electronic tags
Operating system	Proprietary OS
Conformity to standards	CE, FCC class A, Part 15
Display	53 x 95 mm colour OLED touchscreen 272 x 480 pixels resolution
Degree of protection conforming to IEC 60529	IP 40
Memory	RAM: 256 Mb Storage: internal 2 GB + USB socket for memory stick
Reference	XGST2422 (battery, battery charger, 2 GB USB memory stick, and carrying case included with terminal). RFID reader to be ordered separately: XGCS4901201 (integrated reader) or XGW4F111 (remote reader)



Description	for Modbus network		for Ethernet	Pre-wired connector	"T" connector	
	Modbus connecting cable M12 connectors Male / Female	Pre-wired connector M12 male / Bare wires	Modbus connecting cable M12 connectors Female / Mini-DIN 8	Ethernet connecting cable M12 male / RJ 45	Pre-wired supply connector M12 female	Network M12 "T" connector 1 male / 2 female
Application	RS485 connection between a smart antenna and a connection box or between 2 Modbus boxes	Connection between a Modbus box and a Modbus / Uni-Telway network	Connection between an Ethernet box and the Ethernet network	24 VDC supply to connection boxes	For chaining of smart antennas on RS485 network	
L = 2 m	TCSMCN1M1F2	TCSMCN1F2	TCSMCN1F9M2P	XGSZ12E4503 (3)	XGSZ09L2	TCSCN011M11F
L = 5 m	TCSMCN1M1F5	TCSMCN1F5	-	XGSZ12E4510 (4)	XGSZ09L5	

(3) L = 3 m (4) L = 10 m

Field expander	RS232/RS485 converter
----------------	-----------------------

To be associated with a smart antenna XGCS4901201 for conveying and handling applications

For connecting a PC to an OsiSense XG smart antenna.



50 x 400 mm
XGFEC540



250 x 250 mm
XGFEC2525



XGSZ24

Safety sensors Coded magnetic technology

Plastic coded magnetic system

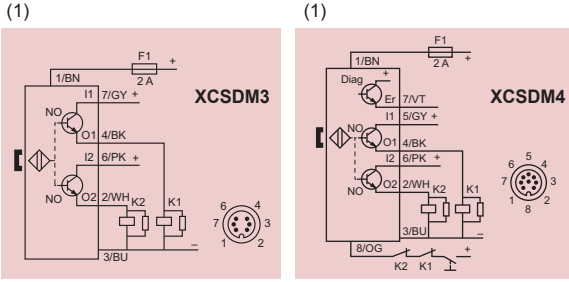

Type of system		SIL2/Category 3	SIL3/Category 4	
With integrated safety module		XCSDM3	XCSDM4	
Maximum safety level		SIL 2 conforming to EN/IEC 61508, PL=d, category 3 conforming to EN/ISO 13849-1	SIL 3 conforming to EN/IEC 61508, PL=e, category 4 conforming to EN/ISO 13849-1	
Switches for actuation		Face to face, face to side, side to side		
Degree of protection		Pre-cabled: IP66 / IP67, IP69K, connector: IP67		
Type of contact		2 solid-state output PNP/NO, 1,5 A / 24VDC (2 A up to 60°C)		
Rated operational characteristics (conforming to EN IEC 60947-5-1)		U _b : 24 VDC +10% - 20%		
Dimensions (mm) W x D x H		34 x 27 x 100		
Operating zone		Sao= 10 mm / Sar= 20 mm		
Reliability data		MTTFd = 182 years; PFH = 3.94E -9; PFD = 1.15E -5; SFF = 92.5%; HFT = 1		
References	Connection	for cable L= 2m	XCSDM379102	XCSDM480102
		for cable L= 5m	XCSDM379105	XCSDM480105
		for cable L= 10m	XCSDM379110	XCSDM480110
		for connector M12	XCSDM3791M12	XCSDM4801M12

Plastic coded magnetic

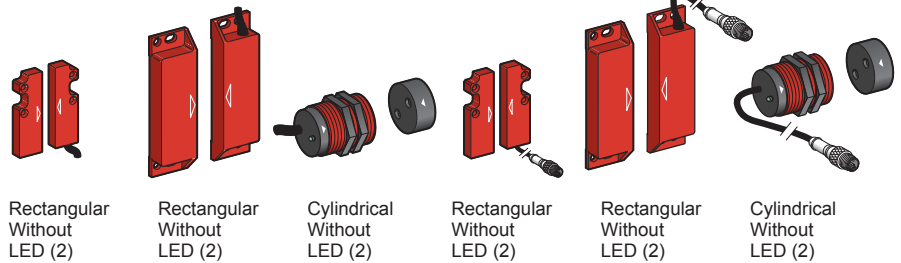
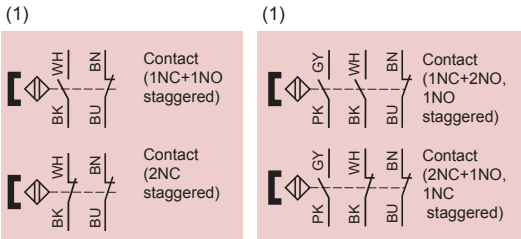

Plastic switches		Type XCSDM coded magnetic					
		Pre-cabled, L = 2 m			Connector on flying lead, L = 15 cm (3)		
Maximum safety level (5)		PL=e, category 4 conforming to EN/ISO 13849-1 and SIL 3 conforming to EN/IEC 61508					
Switches for actuation		Face to face, face to side, side to side	Face to face	Face to face, face to side, side to side	Face to face		
Degree of protection		IP 66 + IP 67					
Type of contact		REED					
Rated operational characteristics (conforming to EN/IEC 60947-5-1)		U _e = 24 VDC, I _e = 100 mA					
Dimensions (mm) W x D x H		16 x 7 x 51	25 x 13 x 88	M30 x 38.5	16 x 7 x 51	25 x 13 x 88	M30 x 38.5 mm
Operating zone (4)		Sao		Sar			
		5	8		5	8	
		15	20		15	20	
Reliability data B10d		50 000 000 (value given for a service life of 20 years, limited by mechanical or contact wear)					
Switch with coded magnet	1NC+1NO staggered	XCSDMC5902	XCSDMP5902	XCSDMR5902	XCSDMC590L01M8	XCSDMP590L01M12	XCSDMR590L01M12
	2NC staggered	XCSDMC7902	XCSDMP7902	XCSDMR7902	XCSDMC790L01M8	XCSDMP790L01M12	XCSDMR790L01M12
	1NC+2NO, 1NO staggered	–	XCSDMP5002	–	–	XCSDMP500L01M12	–
	2NC+1NO, 1NC staggered	–	XCSDMP7002	–	–	XCSDMP700L01M12	–

- (1) Illustration of contacts with the magnet in front of the switch.
- (2) For version with LED indicator, replace the last 0 in the reference by 1 (example: XCSDMC5902 becomes XCSDMC5912).
- (3) For associated pre-wired female connectors, see page 17.
- (4) Sao: assured operating distance. Sar: assured release distance.
- (5) Using an appropriate and correctly connected control system

Safety sensors Coded magnetic technology

Safety modules



Safety modules for monitoring 1 safety function

Maximum safety level of the solution attained (EN ISO 13849-1, EN/IEC 62061)			PL e / Cat. 4, SILCL 3		
For monitoring			2 coded magnetic switches maximum (with 1 N/C + 1 N/O)	6 coded magnetic switches maximum (with 1 N/C + 1 N/O)	1 coded magnetic switch maximum (with 2 N/C)
Number of circuits	Safety		2 N/O	2 N/O	3 N/O
	Additional		2 solid-state	2 solid-state	–
Display (number of LEDs)			3	15	3
Width of housing			22.5 mm	45 mm	22.5 mm
Reference	Supply voltage	24 VDC	XPSDMB1132P (1)	XPSDME1132P (1)	XPSAF5130P (1)

(1) For version with non removable terminal block, delete the letter **P** from the end of the reference (example: XPSDMB1132P becomes XPSDMB1132)

Cabling accessories

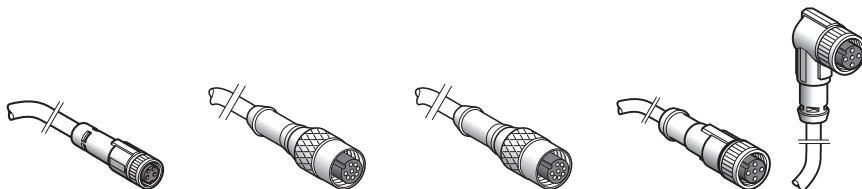

Type of accessory			Pre-wired connectors			
Connector type			Female M8	Female M12	Female M12 (A coding)	Female M12
Number of pins			4	8	8	4
For use with			XCSDMC●●●L	XCSDMP50●L01M12 XCSDMP70●L01M12	XCSDM3●●●M12 XCSDM4●●●M12	XCSDMP59●L01M12 XCSDMP79●L01M12 XCSDMR59●L01M12 XCSDMR79●L01M12
Type	Straight	2 m	XZ CP0941L2	XZCP29P11L2	XZCP29P12L2	XZCP1141L2
		5 m	XZCP0941L5	XZCP29P11L5	XZCP29P12L5	XZCP1141L5
		10 m	XZCP0941L10	XZCP29P11L10	XZCP29P12L10	XZCP1141L10
	Elbowed	2 m	XZCP1041L2	–	–	XZCP1241L2
		5 m	XZCP1041L5	–	–	XZCP1241L5
		10 m	XZCP1041L10	–	–	XZCP1241L10

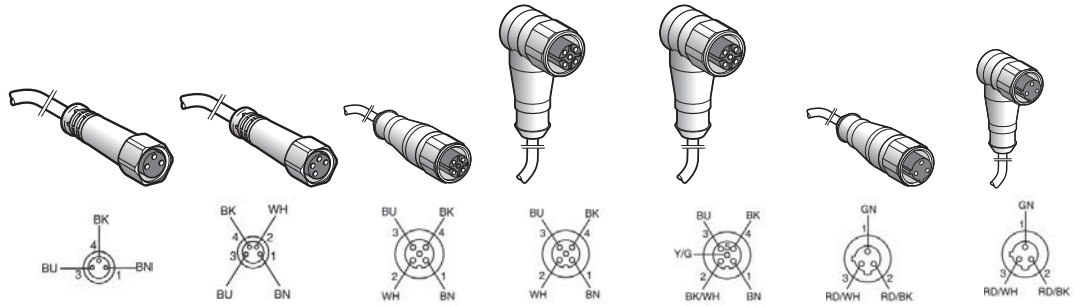

Pre-wired connectors								
Connector type	Female, M8, straight	Female, M8, straight	Female, M12, straight	Female, M12, elbowed	Female, M12, elbowed	Female, 1/2" 20UNF, straight	Female, 1/2" 20UNF, elbowed	
Number of pins	3	4	5	5	5	3	3	
Number of wires	3	4	4	4	5	3	3	
Connection type	Screw threaded, smooth, hexagonal, stainless steel 316L clamping ring (1)							
Degree of protection (conforming to IEC 60529)	IP 68		IP 69K					
Ambient air temperature Static cable usage	- 25...+ 85 °C							
PVC cable, stainless steel ring	L = 2 m	–	–	XZCPA1141L2	XZCPA1241L2	XZCPA1164L2	–	
	L = 5 m	XZCPA0566L5	XZCPA0941L5	XZCPA1141L5	XZCPA1241L5	XZCPA1164L5	XZCPA1865L5	XZCPA1965L5
	L = 10 m	XZCPA0566L10	XZCPA0941L10	XZCPA1141L10	XZCPA1241L10	XZCPA1164L10	XZCPA1865L10	XZCPA1965L10

(1) Tightening by hand recommended.

Jumper cables

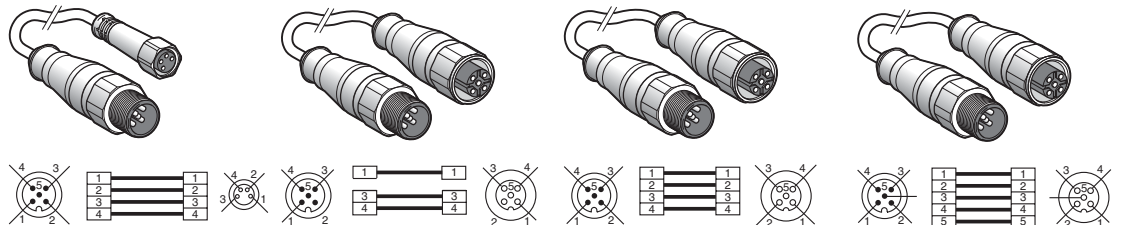

Jumper cables					
Connector type	Female	M8, 4 pin, straight	M12, 5 pin, straight	M12, 5 pin, straight	M12, 5 pin, straight
	Male	M12, 5 pin, straight	M12, 5 pin, straight	M12, 5 pin, straight	M12, 5 pin, straight
Number of wires		4	3	4	5
Connection type	Screw threaded, smooth, hexagonal, stainless steel 316L clamping ring (1)				
Degree of protection (conforming to IEC 60529)	IP 69K				
Ambient air temperature Static cable usage	- 25...+ 85 °C				
PVC cable, stainless steel ring	L = 2 m	XZCRA150941J2	XZCRA151140A2	XZCRA151141C2	XZCRA151164D2
	L = 5 m	XZCRA150941J5	XZCRA151140A5	XZCRA151141C5	XZCRA151164D5

(1) Tightening by hand recommended.



Rigid reflectors					
Dimensions (mm)	50x70	50x70	40x60	Ø84	100X100
Fixing mode	6 holes		2 holes	one hole	2 brackets
Chemical resistance	No				
High precision	No	Yes	No		
Degree of protection (conforming to IEC 60529)	IP 67 / IP 69K				
Operating temperature	-20 °C to +60 °C				
References	XUZC50	XUZC50HP	XUZC60S11	XUZC80	XUZC100
Compatibility and effect on sensing range					
Cylindrical M18 Food & Beverage processing	100%	–	80%	130%	135%
Cylindrical M18 Transparent material	–	100%	–	–	–
Compact XUK stainless steel	100%	–	80%	150%	180%
Compact XUK Laser beam	–	–	–	–	–



Rigid reflectors				
Dimensions (mm)	20x32	18x60	19x60	50x70
Fixing mode	2 holes			6 holes
Chemical resistance	yes			
High precision	yes	no	yes	no
Degree of protection (conforming to IEC 60529)	IP 67 / IP 69K			
Operating temperature	-20 °C to +140 °C			
References	XUZCR0201CRHP	XUZCR0402CR	XUZCR0401CRHP	XUZC50CR
Compatibility and effect on sensing range				
Cylindrical M18 Food & Beverage processing	–	30%	–	50%
Cylindrical M18 Transparent material	20%	–	25%	–
Compact XUK stainless steel	–	30%	–	50%
Compact XUK Laser beam	10%	–	15%	–

ECOLAB Certification

Example from XUKS

Ecolab is a well established industrial standard within industries where chemical and cleaning products are frequently used.

The ECOLAB certificate guarantees the resistance of the sensors for the food and beverage processing industry.

This certificate is based on:

- documented test procedures (test no.: F&E/P3-E Nr. 40-1) according to material resistance
- defined product descriptions
- standardized cleaning procedure

Test procedure Ecolab-test F&E Nr. 40-1

Dipping test:

- Complete immersion in solutions/liquid

Test period:

- 28 days

Temperature:

- room temperature (constant)

Analysis:

- Visual judgement like swelling, brittleness, discoloring
- compared to zero-reference factor (demineralized water)
- Photo documentation
- Based on Analysis no.51-08

Product specifications:

P3-topactive DES

Acid disinfectant based on peracetic acid/hydrogen peroxide for the food and beverage industry

P3-topax 19

Alkaline, chlorine-free foam cleaner for the food and beverage industry

P3-topax 56:

Acid foam cleaning substance for the food and beverage industry

P3-topax 91:

Neural disinfectant based on Quaternary Ammonium Compounds (QAC) for the food industry

Cleaning plan for food and beverage industry*



Rinsing with water 40 – 50°C

Rinsing with low pressure. Rinsing from top to bottom in the direction of the drains. Cleaning of the drains.



Foaming from bottom to top

alkaline: P3-topax 19 2 – 5 % daily
 acid: P3-topax 56 2 % on demand
 temperature: cold up to 40°C
 contact time: 15 min. recommended



Rinsing with water 40 – 50°C

Rinsing from top to bottom with low pressure

Spray disinfection: P3-topax 91 1-2 %; 30-60 min

Foam disinfection : P3-topactive DES 1-3 %, 10-30 min

*short description

Technical information

Degrees of protection provided by enclosures IP code

IP ●●● code

The IP code comprises **2 characteristic numerals** (e.g. **IP55**) and may include **an additional letter** when the actual protection of personnel against direct contact with live parts is better than that indicated by the first numeral (e.g. IP 20C). Any characteristic numeral which is unspecified is replaced by an X (e.g. IP XXB).

1st characteristic numeral:















corresponds to protection of the equipment against penetration of solid objects and protection of personnel against direct contact with live parts.

2nd characteristic numeral:

corresponds to protection of the equipment against penetration of water with harmful effects.

Additional letter:

corresponds to protection of personnel against direct contact with live parts.

Protection of the equipment		Protection of personnel	
0	Non-protected	0	Non-protected
1	 Protected against the penetration of solid objects having a diameter greater than or equal to 50 mm.	1	 Protected against direct contact with the back of the hand (accidental contacts).
2	 Protected against the penetration of solid objects having a diameter greater than or equal to 12.5 mm.	2	 Protected against direct finger contact.
3	 Protected against the penetration of solid objects having a diameter greater than or equal to 2.5 mm.	3	 Protected against direct contact with a Ø 2.5 mm tool.
4	 Protected against the penetration of solid objects having a diameter > 1 mm.	4	 Protected against direct contact with a Ø 1 mm wire.
5	 Dust protected (no harmful deposits).	5	 Protected against direct contact with a Ø 1 mm wire.
6	 Dust tight.	6	 Protected against direct contact with a Ø 1 mm wire.
		7	 Protected against the effects of temporary immersion.
		8	 Protected against the effects of prolonged immersion under specified conditions.

Test IP 69K

IP 69 K

Conforming to DIN40050, part 9: protected against water during high pressure/steam cleaning.

- + High temperature (+ 80 °C)
- + High pressure (100 bar).
- + Test duration (3 minutes)

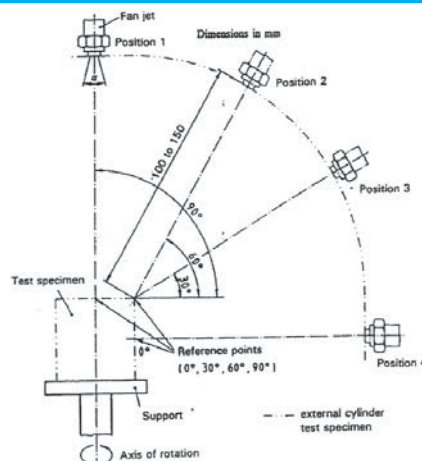

The high pressure water test is made according to Standard(s):
 DIN 40050-9 (1993);
 IEC 60529 Ed. 2.1 (2001);
 IEC 60947-1 Ed. 5 (2007);
 IEC 60947-5-2 Ed. 3 (2007).



Flash this code and discover the IP69K test for XUKS

Schneider Electric Industries SAS

Head Office
35, rue Joseph Monier - CS 30323
F92500 Rueil-Malmaison Cedex
France

www.tesensors.com

The information provided in this documentation contains general descriptions and/or technical characteristics of the performance of the products contained herein. This documentation is not intended as a substitute for and is not to be used for determining suitability or reliability of these products for specific user applications. It is the duty of any such user or integrator to perform the appropriate and complete risk analysis, evaluation and testing of the products with respect to the relevant specific application or use thereof. Neither Schneider Electric nor any of its affiliates or subsidiaries shall be responsible or liable for misuse of the information contained herein.

Design : IGS-CP
Photos : Schneider Electric
Print :

DIA4ED2130706EN