

Gateways | Link150

Gateways and Energy Servers Portfolio

Function

The Link150 serves as an Ethernet Gateway for Powerlogic system devices and any other communicating devices utilizing the Modbus protocol. The Link150 gateway offers complete access to status and measurement information provided by the connected devices via software.

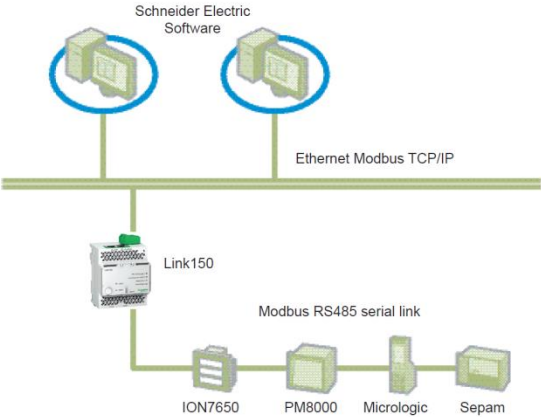

Gateways | Link150

Gateways and Energy Servers Portfolio

Main Features

The main features of the Link150 are:

- Transparent Gateway for MODBUS TCP to MODBUS RTU
- High performance communication
- Two (2) Ethernet ports for daisy chain ethernet
- RS232 serial port & RS485 serial port for serial connection
- Setup through convenient built-in web pages
- Compliant with electrical switchboard environment (temperature, electromagnetic compatibility)
- 4 supported transfer protocols: HTTP, HTTPS, FTP, and SNMP
- IPV6 Support
- 24V DC and/or POE power supply



Gateways | Link150

Gateways and Energy Servers Portfolio



From a single building, to a multi-site enterprise, the **Link 150** provides fast, reliable Ethernet connectivity in the most demanding applications:

- Energy management
- Power distribution
- Building automation
- Factory automation

“simple, cost effective serial line to Ethernet connectivity”



Easy to install. Easy to setup. Easy to maintain.



Compatible with PowerLogic Software. {PowerSCADA Expert, Power Monitoring Expert, etc.}



Reliable Modbus to Ethernet Protocol Conversion.



Easy to install. Easy to setup. Easy to maintain.

Install

- Self Grounding Din Rail Mount
- Plug & Play Connectors
- Power Over Ethernet eliminates the need for CPTs, disconnects, and AC-DC power supplies, while greatly reducing installation time.

Setup

- All setup through web pages – no customer software to install
- DHCP for dynamic IP address
- IPV6 link local address supported
- DPWS – Automatically find the Link150 through Windows Network Settings

Maintain

- Field upgradable firmware lets you add new features while reducing costly downtime
- Communication errors and network information available on web pages
- No regular maintenance required on the hardware



Compatible with PowerLogic Software. {PowerSCADA Expert, Power Monitoring Expert, etc.}

TVDA**

- **Tested, Validated, Documented Architectures
- PowerScada Expert
- Power Monitoring Expert



Reliable Modbus to Ethernet Protocol Conversion.

Reliable

- Tested, Validated, Documented Architectures
- Transparent gateway for any modbus device
- System Technical Note – Document describing best practices and device qty per modbus serial line.

Gateways | Link150 > Architecture – Master Mode

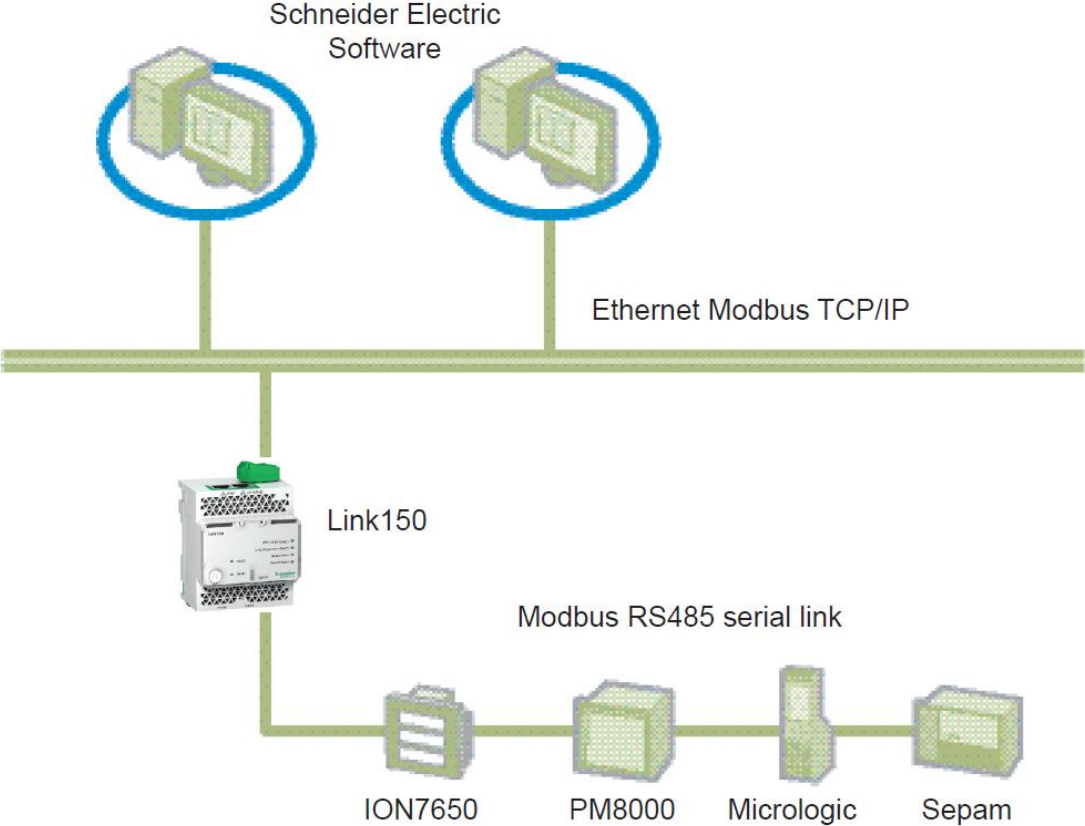

Gateways | Link150 > Architecture – Slave Mode

Slave Mode:

Serial Master can address downstream slaves over Ethernet.
In the example below the PLC master can either address the Ethernet Slave or the Serial Slaves.

